

LEGACY
STOVES™

Advanced Design
Old Fashioned Value



SUPER MAGNUM
COAL STOKER



ADVANCED DESIGN OLD FASHIONED VALUE

Optional brushed stainless steel air grille

Vented hopper holds up to 110lbs of anthracite coal

Quiet, variable speed blower

Optional stainless steel trim

Exclusive glass air wash system

Secure door latches

Optional slate tile accent

Large, easy-access ash pan

Air filter

Hidden leg height adjustments



SUPER MAGNUM STOKER

Bring warmth into your home, and comfort into your lifestyle. The Super Magnum Stoker is built with distinctive Legacy Stoves craftsmanship to deliver easy, clean and powerful precision heating.

Two exclusive technologies function together in the Super Magnum to create award-winning home heating performance. The Verti-Flow™ feed system maximizes efficiency and fire control, while ESP technology is constantly monitoring and adjusting heat output to set temperatures within 1 degree.

Experience 100+ hour burn times, 100,000+ BTUs and Legacy Stoves quality for years to come with the Super Magnum Stoker.



ANTHRACITE COAL FUEL

Domestically discovered in Pennsylvania more than 200 years ago, Anthracite coal is dense, compact and known for having few impurities. Its low sulfur and high carbon content help make it exceptionally clean-burning.

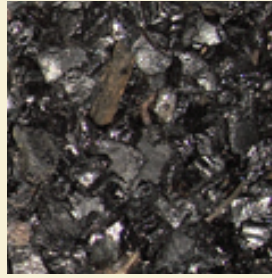

Even better, Anthracite is less expensive than oil, less labor-intensive than firewood and burns cleaner than both. Virtually no smoke or emissions are produced, and ashes can be safely recycled back into the environment, helping aerate soil or used as anti-skid material.

FEATURES & OPTIONS

Distinctive features offer convenience, safety and style.

Features

- 105,000 BTU/Hour Input—heats 2,000 to 5,300 square feet!
- 110lb. hopper capacity
- More than 100 hours of burn time from each load of coal
- Exhaust sensing technology constantly monitors and adjusts heat levels
- Air filter ensures optimal air quality

Options

- Brushed stainless steel door trim
- Decorative slate tile accent
- Heat transfer kit
- Battery backup

Slate Tile Accents



Heat Transfer Kit

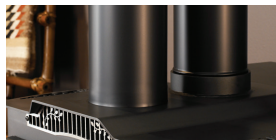

A cross-section illustrates how combustion air flows through the Super Magnum and exits as clean, powerful heating.

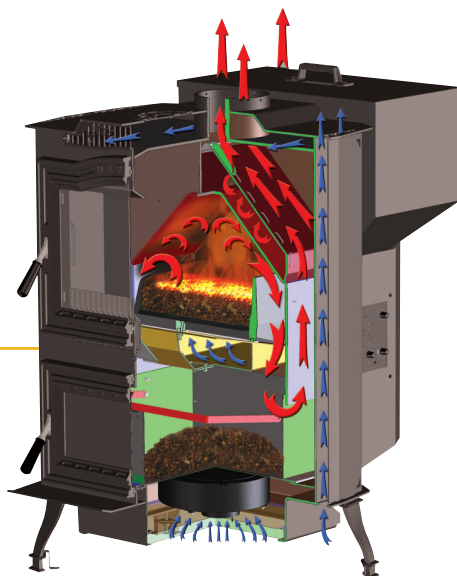

VertiFlow™ Coal Stoker

The VertiFlow™ Stoker System burns each piece of coal thoroughly and completely—for amazing fire control, maximum heat and impressive burn times. Coal is fed from the bottom of the hopper and automatically controlled based on heating demands.

Scan with your smartphone to learn more about the VertiFlow Stoker System, or visit LegacyStoves.com



ESP Temperature Control

The Super Magnum utilizes an advanced Exhaust Sensing Probe (ESP) system to deliver precision heating control. ESP constantly monitors and adjusts heat output to maintain set room temperatures within 1 degree.

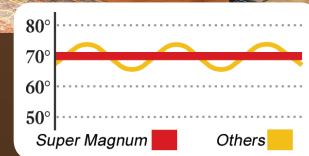

ESP temperature control helps maintain a consistent room temperature.

Scan with your smartphone to learn more about ESP Temperature Control, or visit LegacyStoves.com.



SPECIFICATIONS

SUPER MAGNUM COAL STOKER	BTU Range	Heating Capacity*	Hopper Capacity	Fuel Type	Blower Size	Flue Size	Fuse Rating	Feed Rate	Ship Weight	Depth	Height	Width	Min. Floor Protection
	5,000 - 105,000	up to 5,300 sq. ft.	110 lbs.	Anthracite Rice Coal	135 cfm	6"	3 amp	0.5 lb/hour (min) 8.75 lbs/hr (max)	543 lbs.	35.3"	42"	26.7"	49.5" x 42.75"

Dimensions

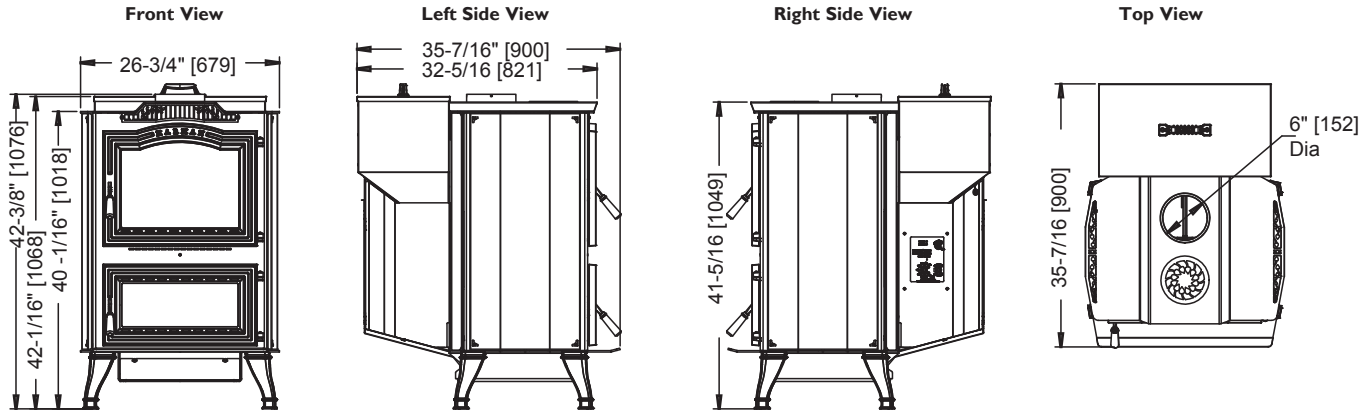

Floor Protection

	Floor Protection	Inches	Millimeters
G	Sides - USA/CANADA*	8"	203
H	Front - USA/CANADA*	18"	457
J	Rear - USA	12"	305

Minimum Size floor protection is 49-1/2" deep By 42-3/4" wide.

* Minimum size floor protection for a corner installation hearth pad is 54" x 54" (USA ONLY).

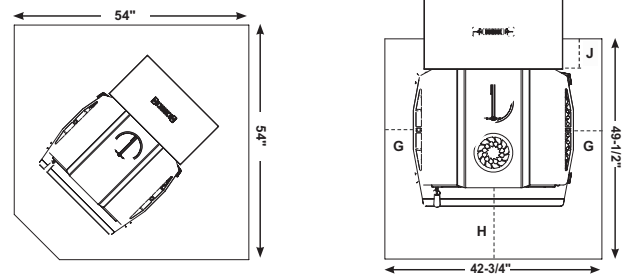

Clearances to Combustibles

Standard Installation		US	Canada
A	Back Wall To Unit Hopper	2"	51mm
B	Side Wall To Unit	24"	610mm
C	Back Wall To Flue Connector	17"	432mm
D	Side Wall To Flue Connector	34"	864mm
Corner Installation		US	Canada
E	Walls to Unit Body	15"	381mm
F	Walls to Flue Connector	24"	610mm

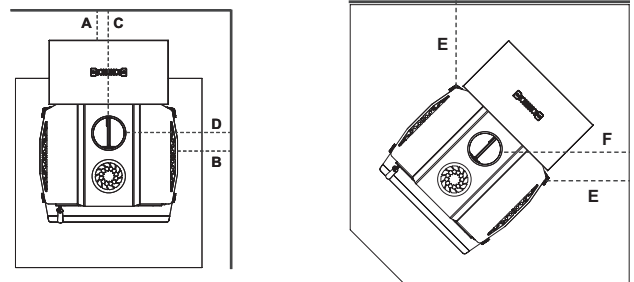

YOUR LEGACY STOVES DEALER IS:

LEGACY STOVES™

Advanced Design
Old Fashioned Value

A brand of Alternate Heating Systems
 2393 LITTLE EGYPT RD
 HARRISONVILLE PA 17228

facebook.com/altheatsys
 www.legacystoves.com
 www.alternateheatingsystems.com

LIMITED LIFETIME WARRANTY²

One of the best in the industry, AHS provides a limited lifetime warranty on most important aspects: firebox and heat exchanger.

¹See your local authorized Legacy dealer for help in determining the product that best suits your heating needs based on climate and home efficiency.

²For full warranty details, visit www.legacystoves.com

Actual product appearance, including flame, may differ from image. Product specifications and pricing subject to change without notice. The images and descriptions in this brochure are provided to assist you in product selection only. Refer to installation manual for complete clearance requirements and specifications.

Fireplace, stove and insert surfaces get extremely HOT and can cause severe burns if touched. Keep a safe distance away.